

男子団体戦

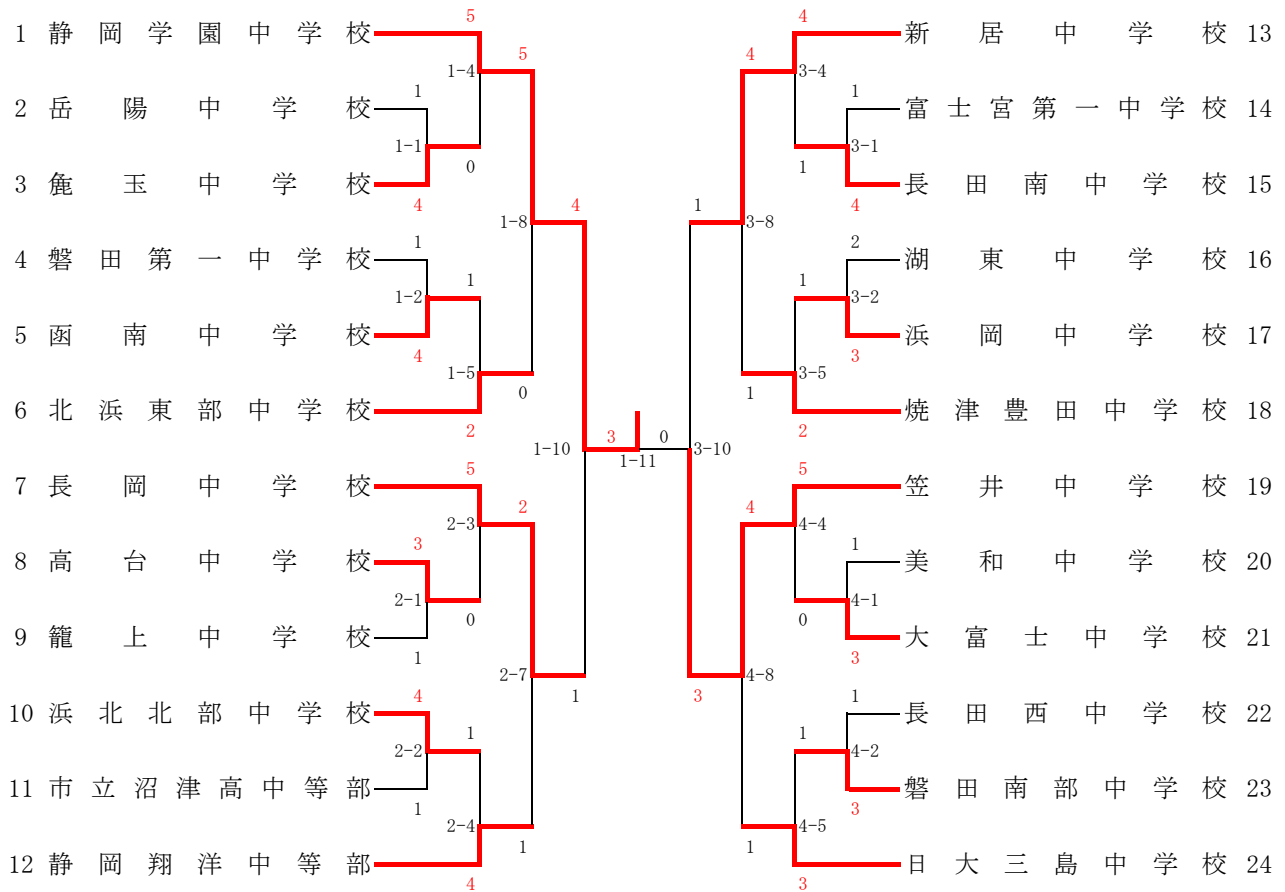

女子団体戦

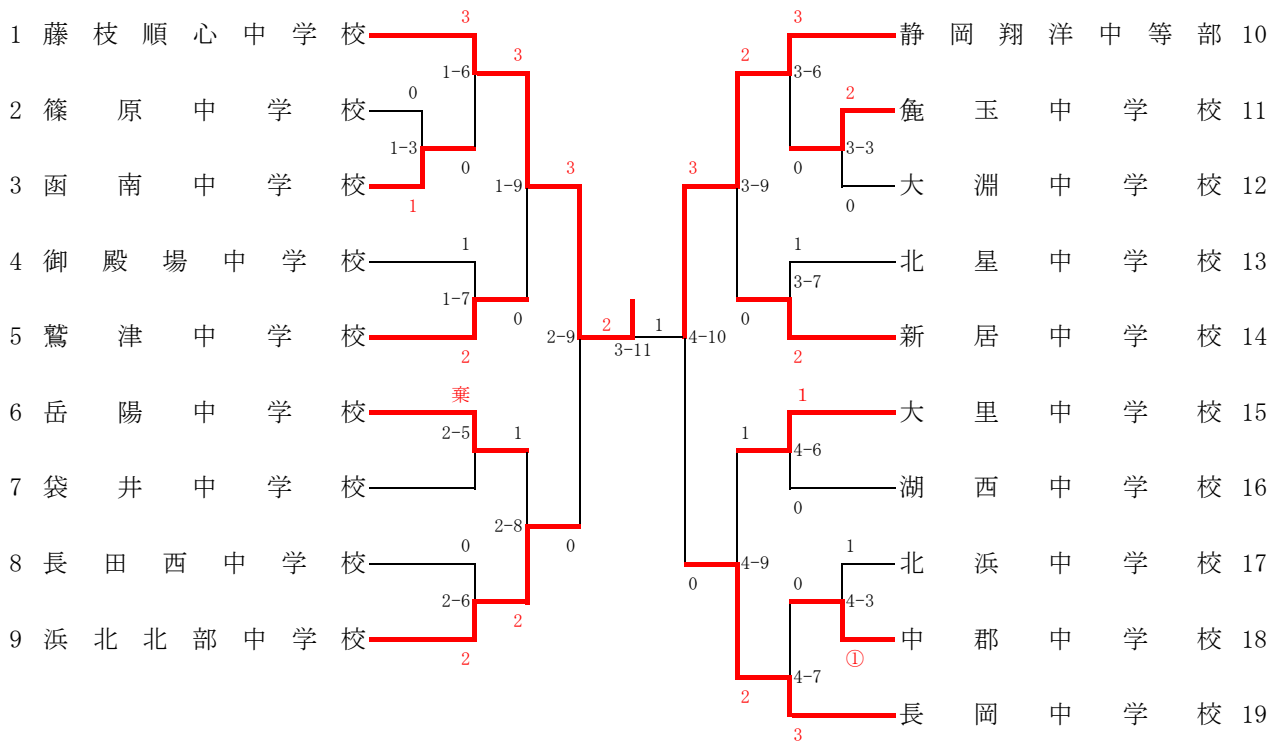

男子50kg級

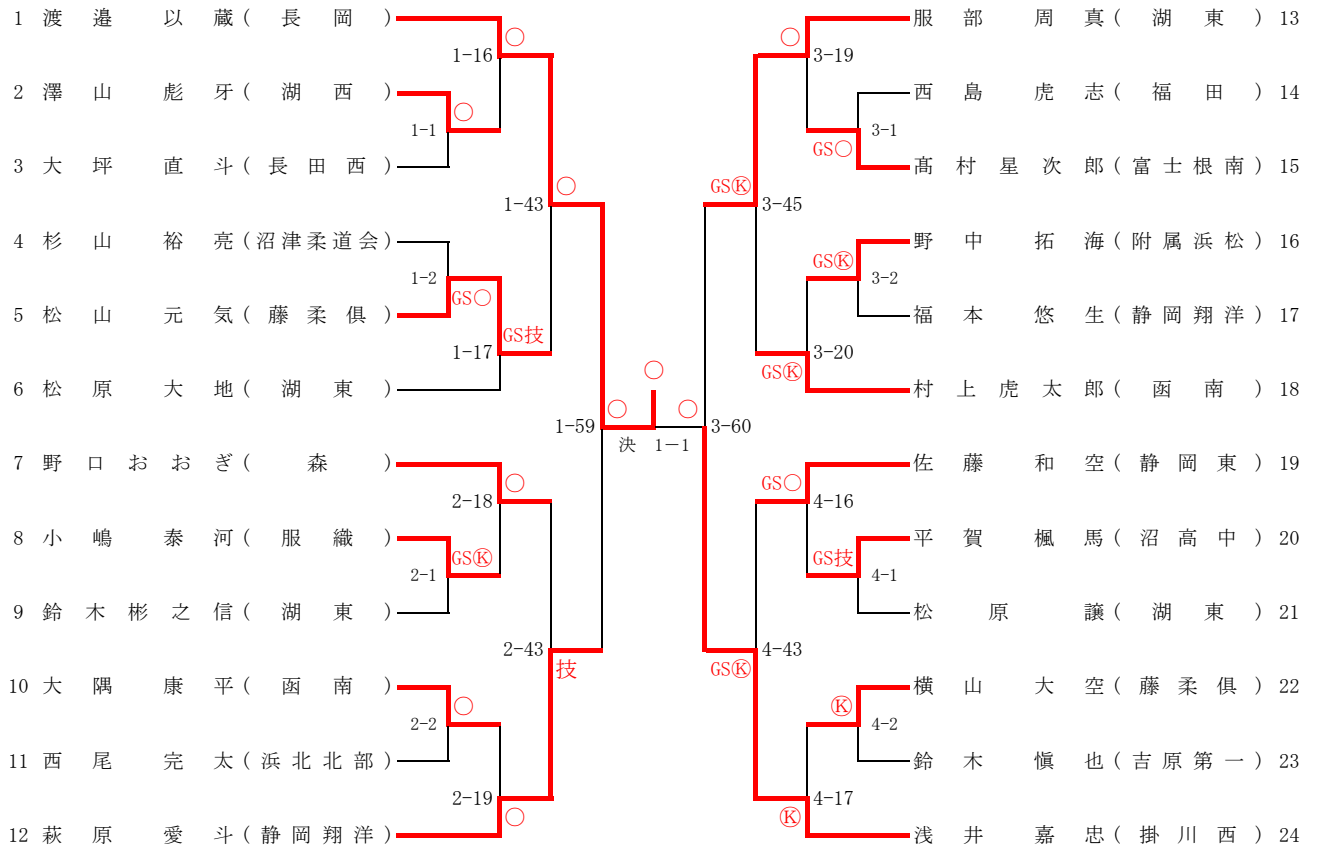

男子55kg級

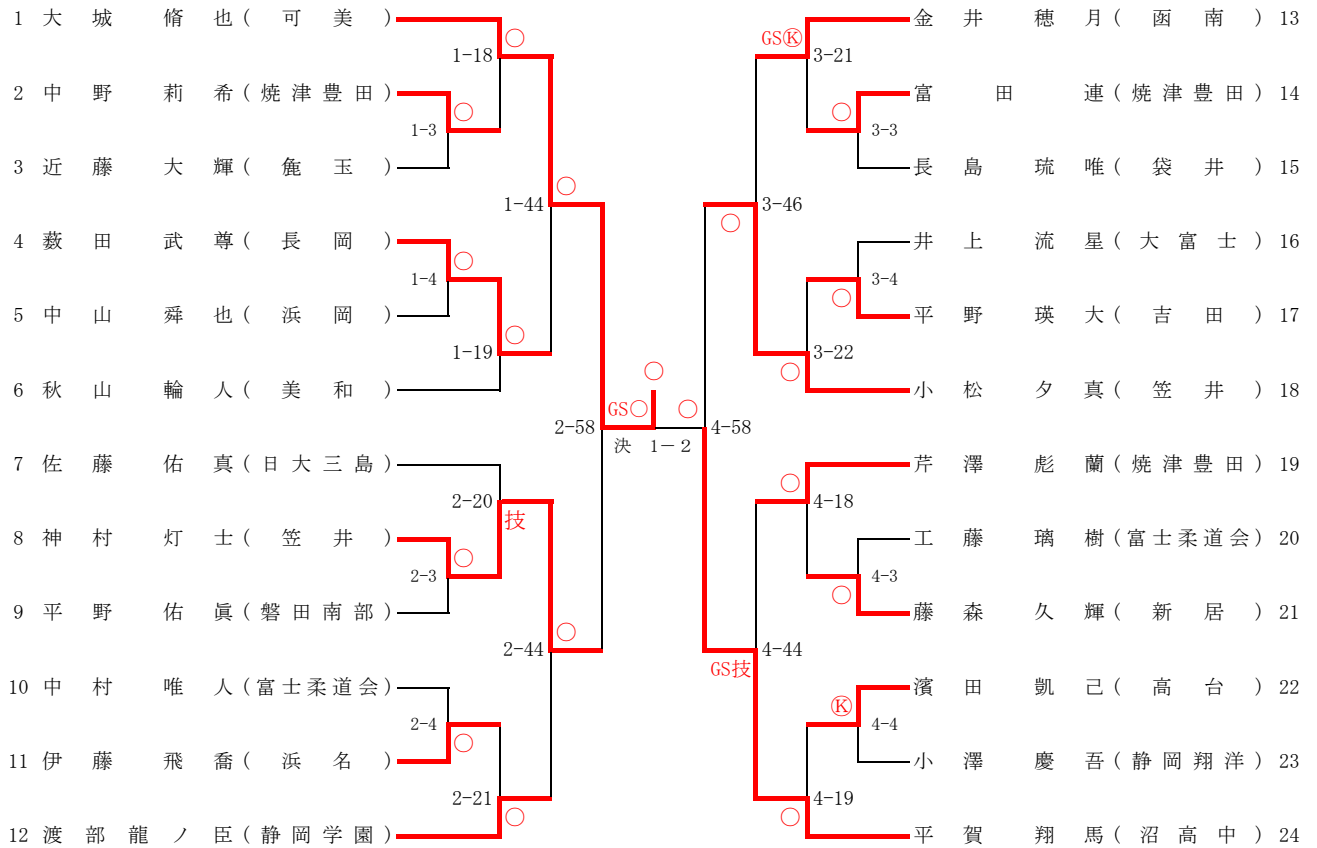

男子60kg級

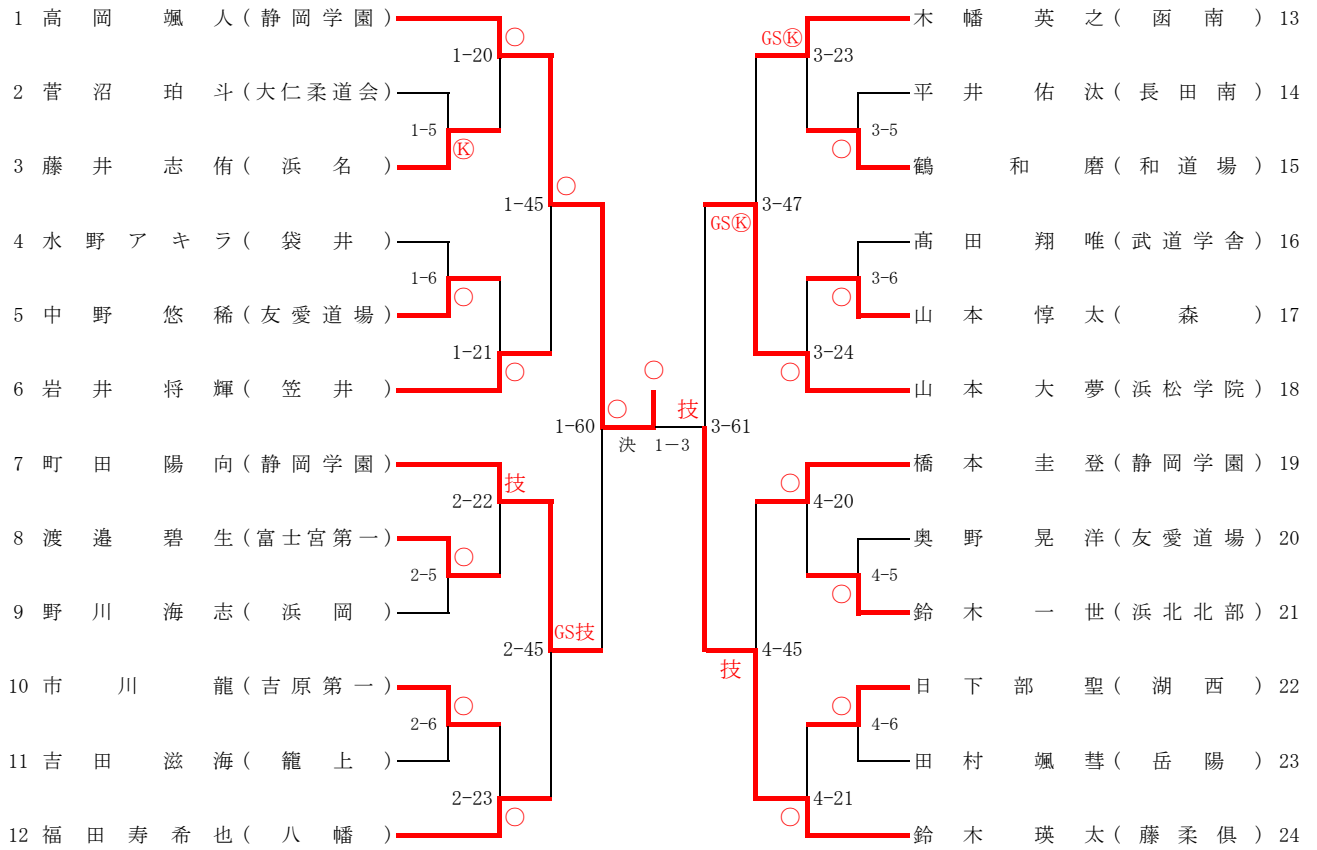

男子66kg級

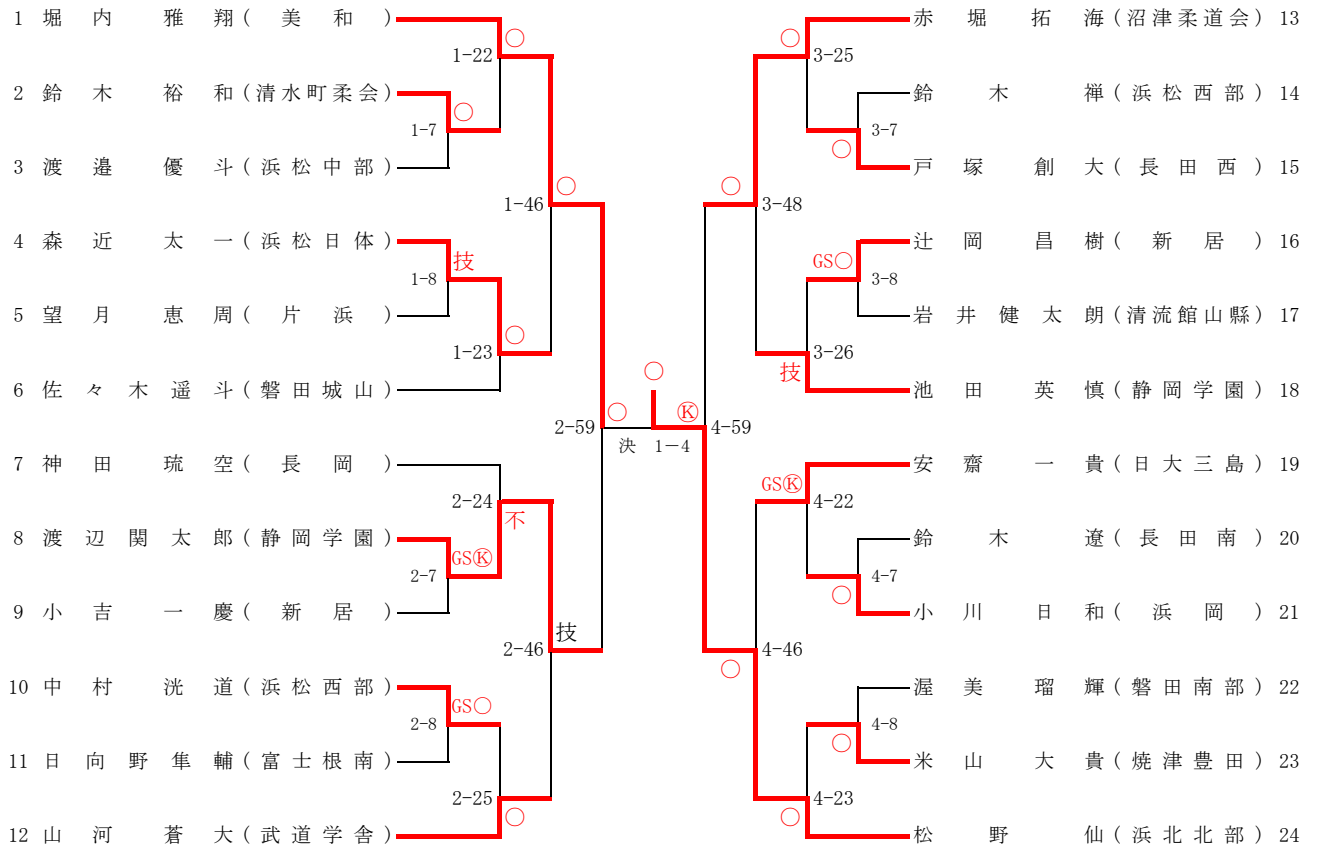

男子73kg級

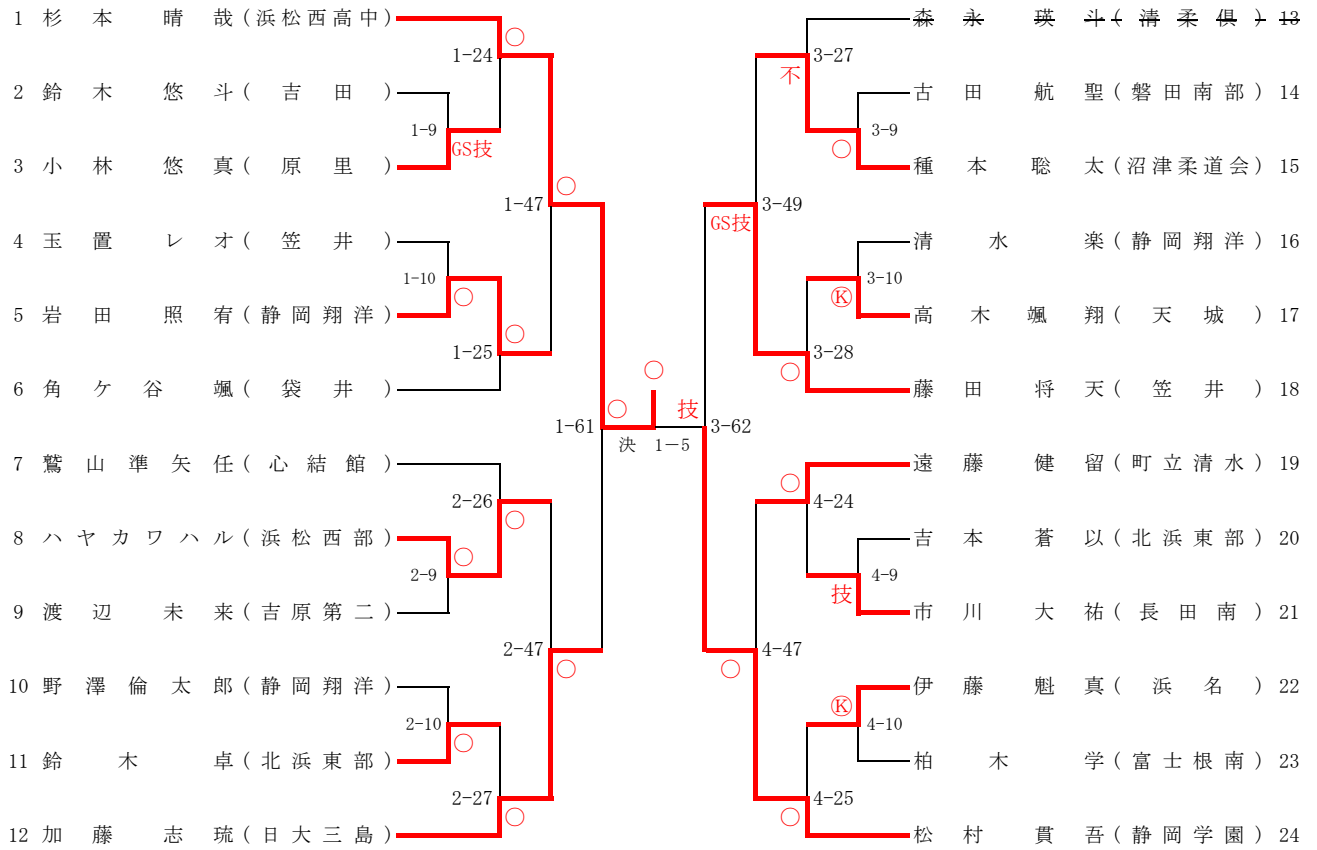

男子81kg級

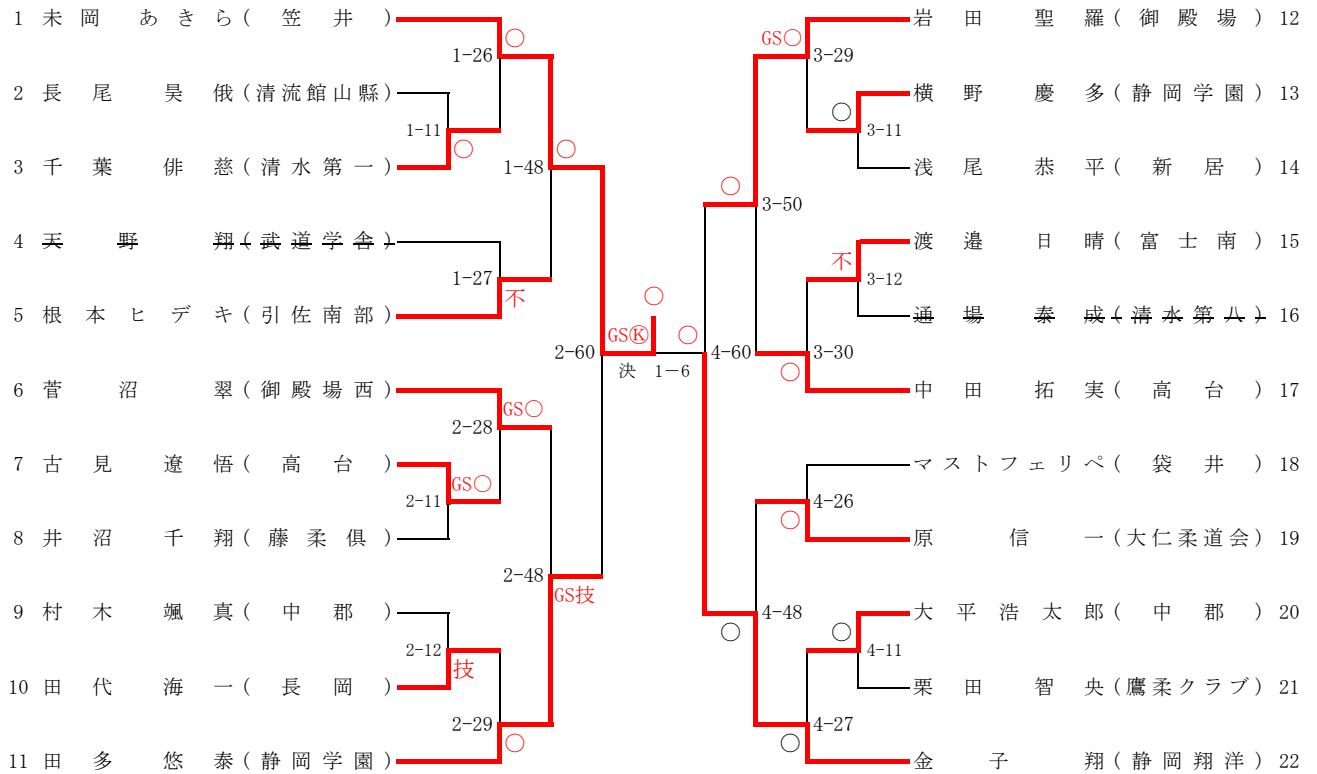

男子90kg級

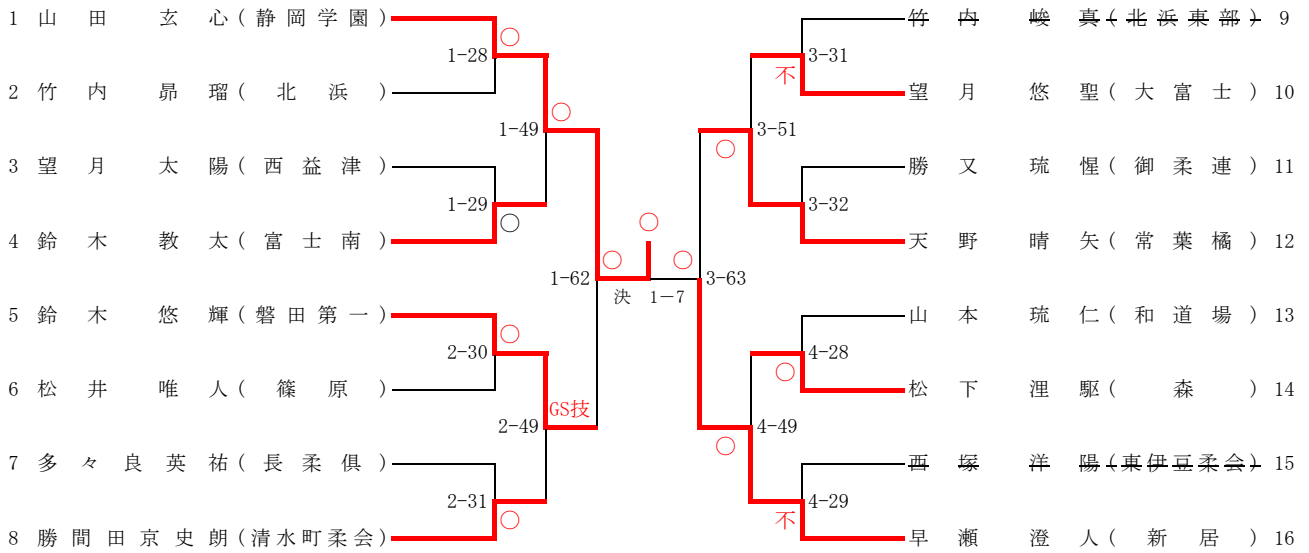

男子90kg超級

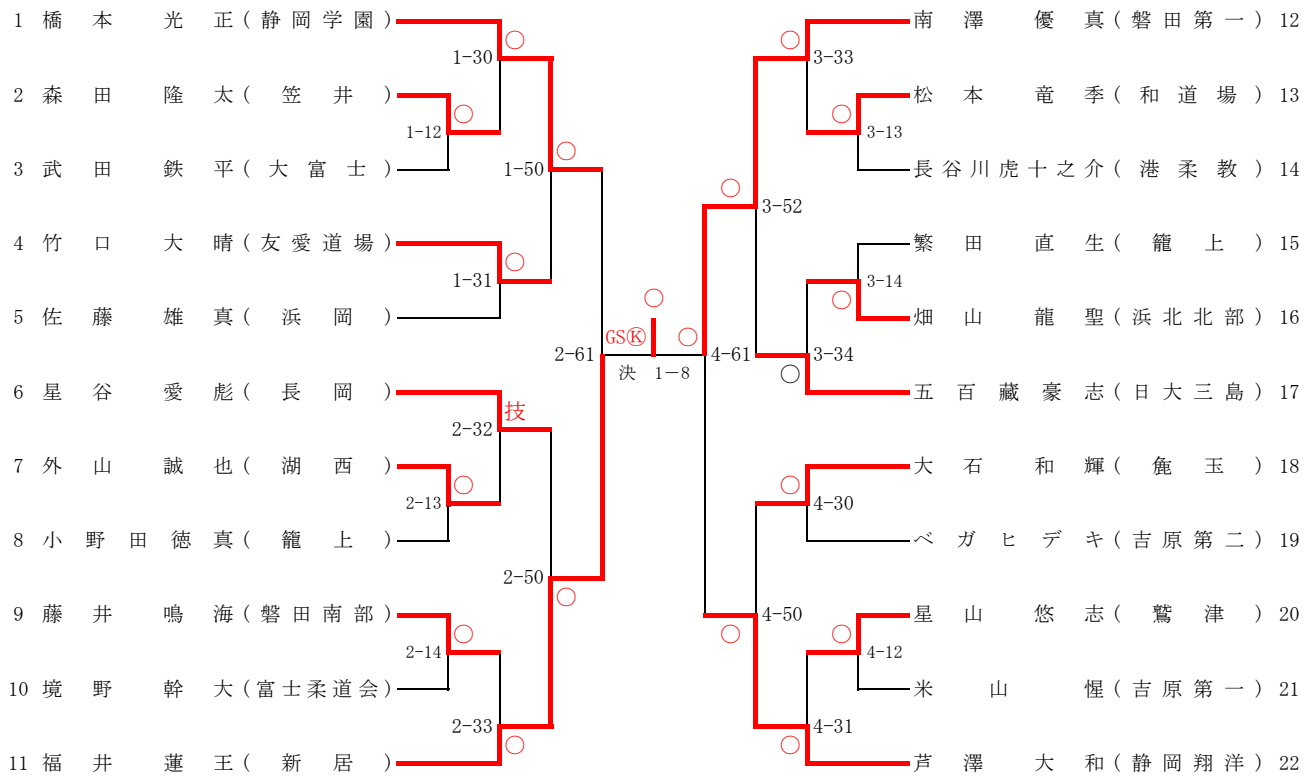

女子40kg級

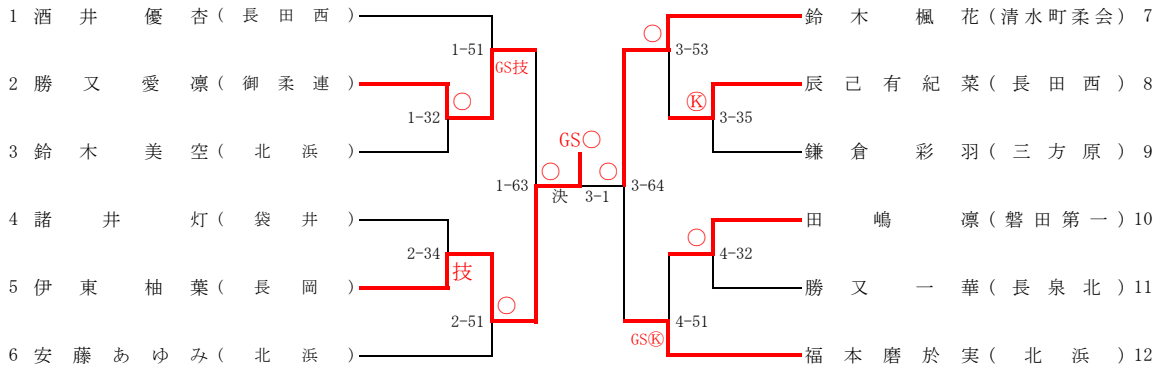

女子44kg級

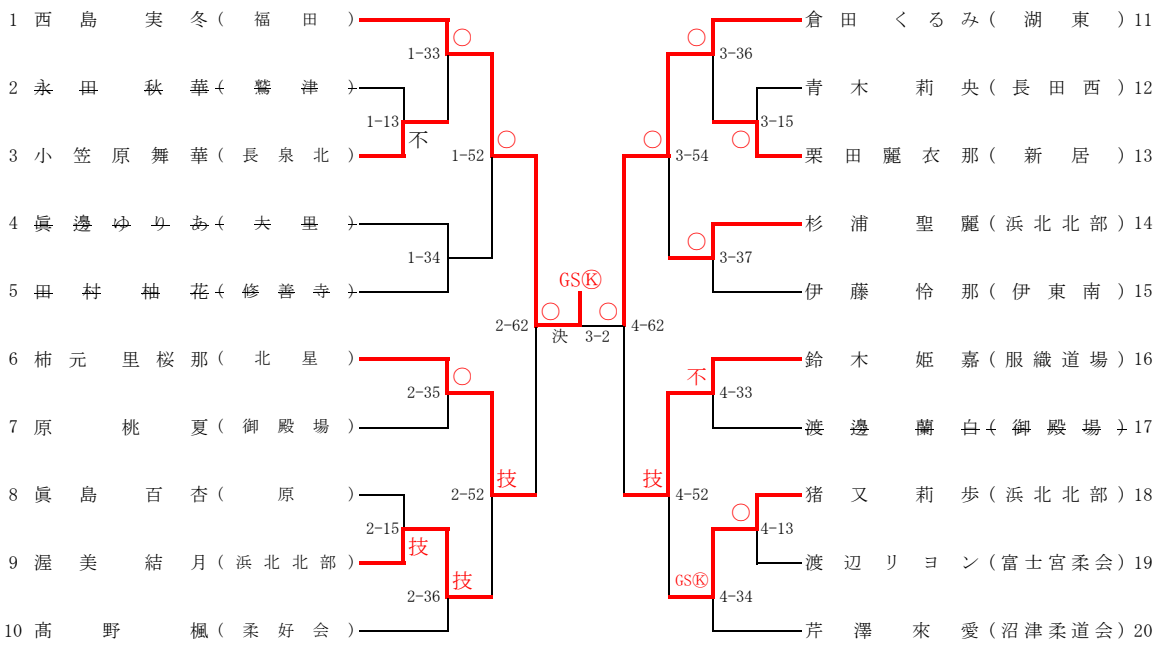

女子48kg級

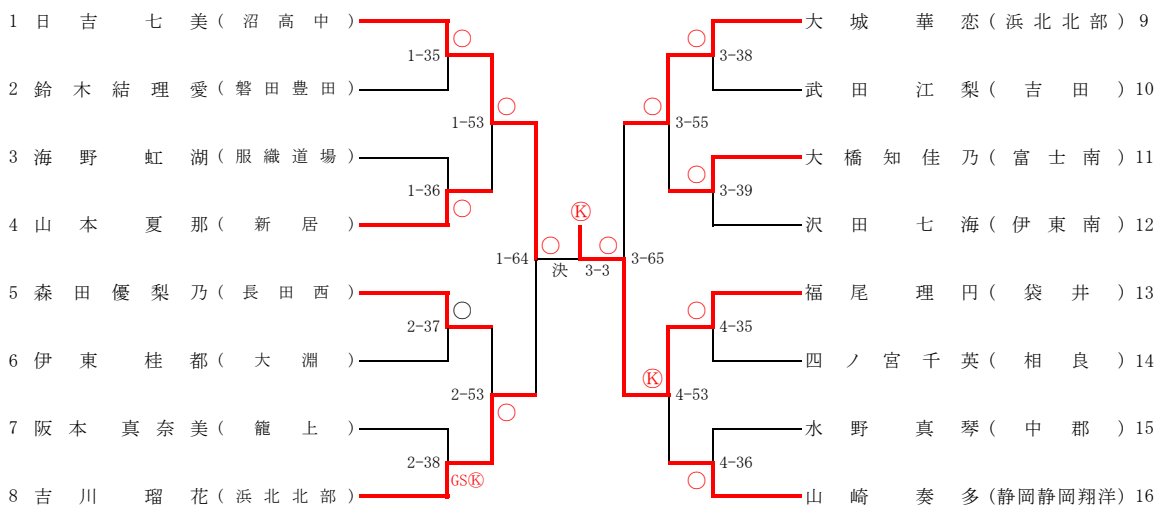

女子52kg級

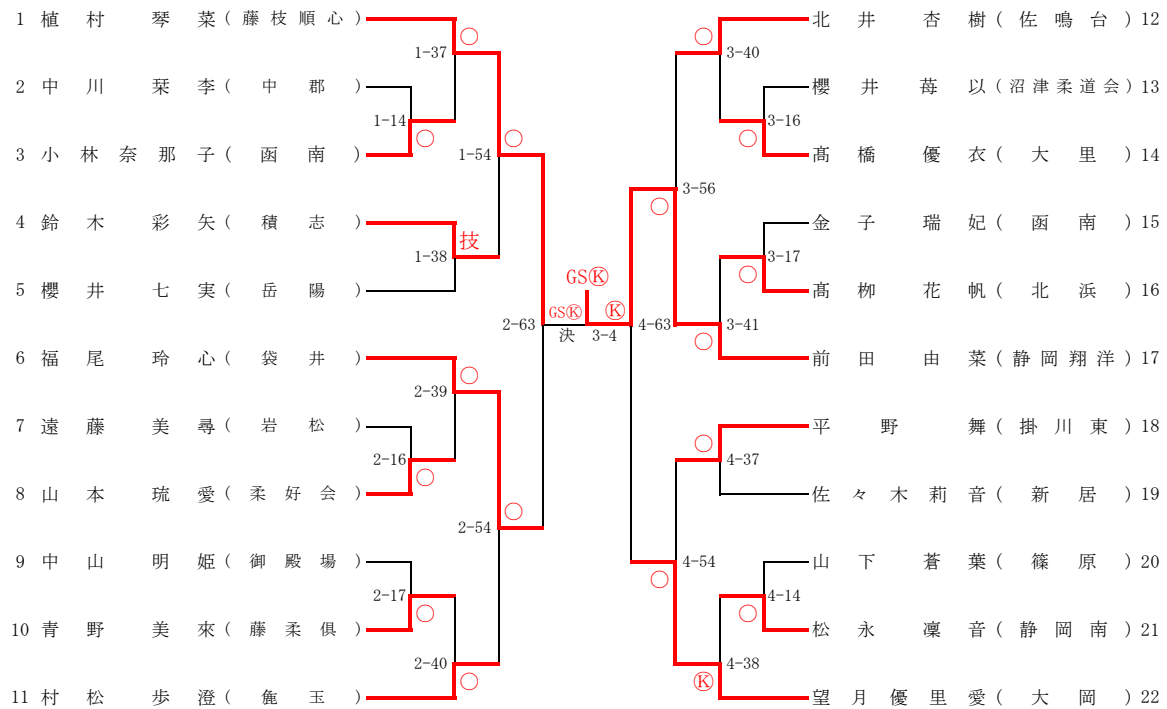

女子57kg級

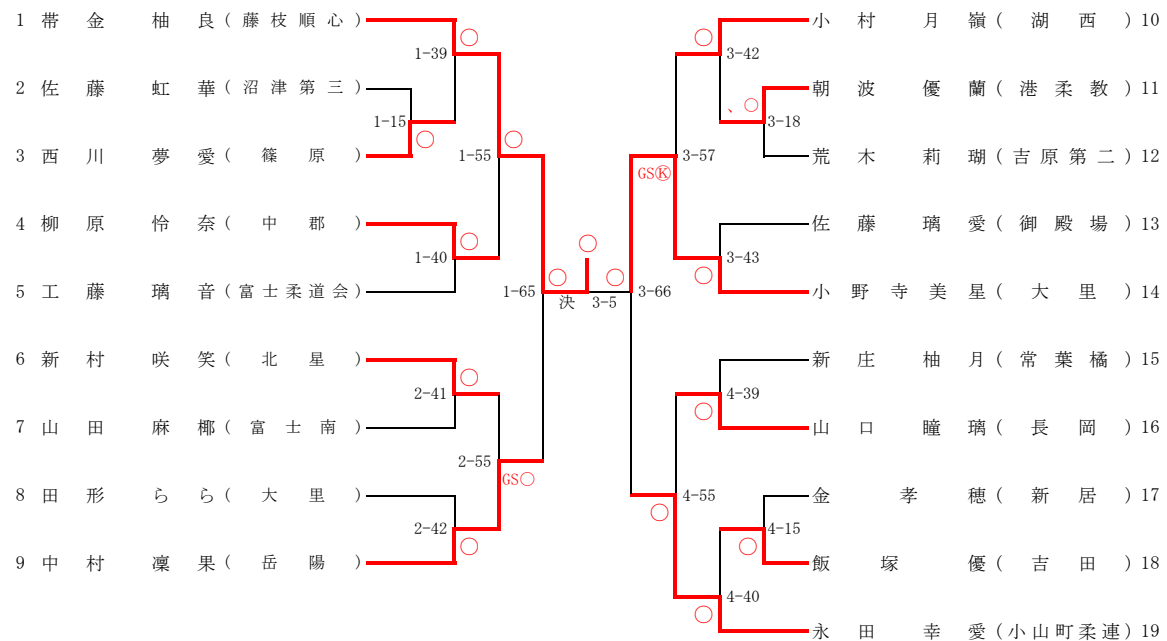

女子63kg級

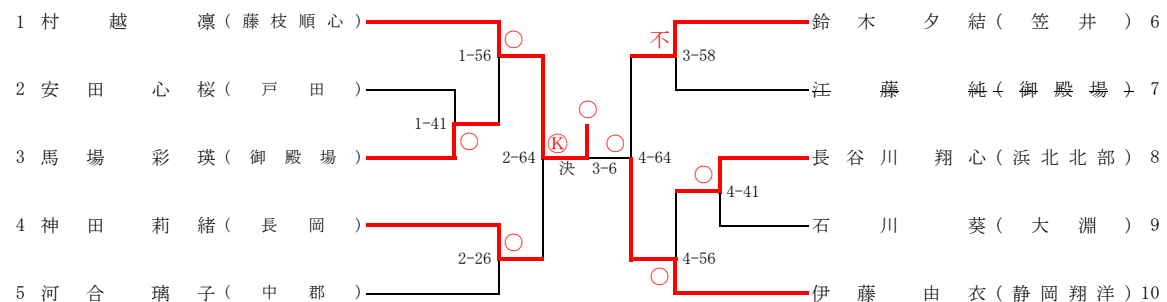

女子70kg級

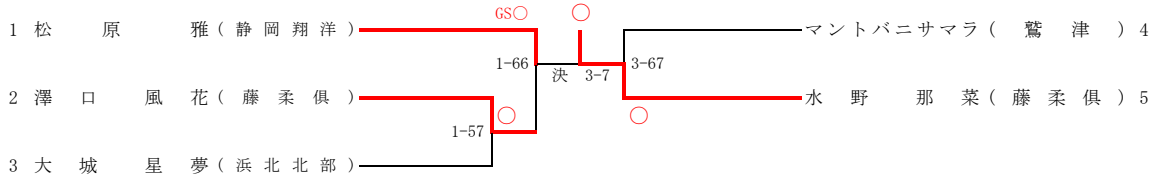

女子70kg超級

